

COMBINATION ISOLATORS

Combination isolators provide the excellent shock absorbing properties of rubber in shear and compression with good dynamic cushioning under rugged operating conditions.

These isolators are designed to be used as an assembly. The rebound unit limits the free movement of the equipment to some extent, but this restriction is very desirable in mobile installations. Care must be taken when installing to ensure that the nut is not drawn too tightly so as to avoid any excessive pre-loading of the isolator and rebound unit.

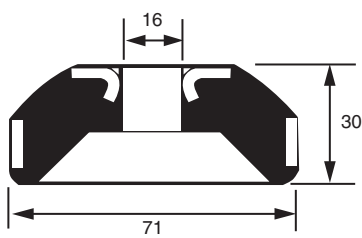

M104

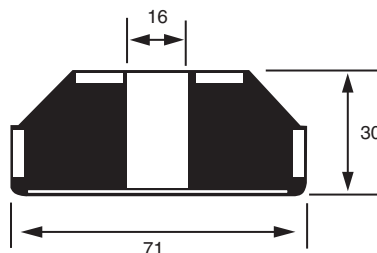

M204

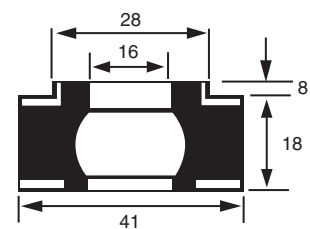

M107

Part No.	LOAD Kg	DEF. mm	Duro	WEIGHT Kg
M10440	57	4	40	0.2
M10450	90	4	50	0.2
M10460	125	4	60	0.2
M10470	180	4	70	0.2
M204	270	4		0.2
M10740	115	4	40	0.05
M10750	170	4	50	0.05
M10760	250	4	60	0.05
M10770	280	4	70	0.05

TYPICAL MOUNTING SYSTEMS

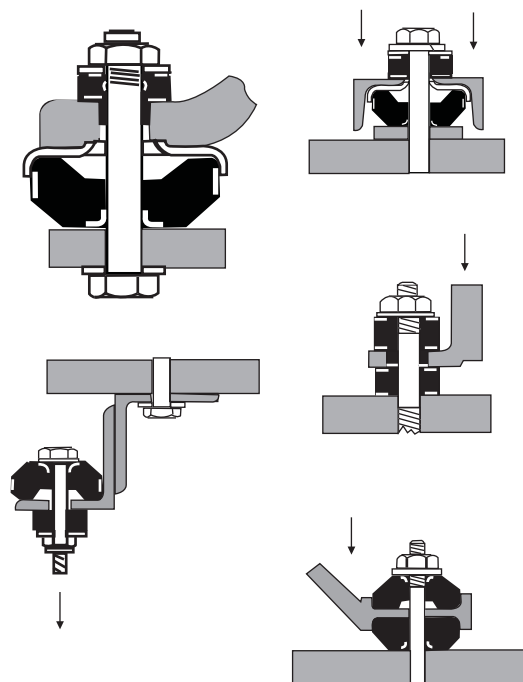

COLOUR CODE

DURO	COLOUR
40	Red
50	Yellow
60	White
70	Marked 70