

HY-DEFLECTION ISOLATORS

Hy-Deflection Isolators provide flexible support for mechanical apparatus which is subject to intermittent or continuous, low frequency, high amplitude vibration. The design provides soft spring rate quality in all directions with exceptional horizontal stability.

APPLICATIONS:

Hy-Deflection Isolators are traditionally used in equipment where a high degree of vibration isolation is required, such as; Vibrating Screens, Vibrating Conveyors, Generators, Industrial Refrigeration Units, Air Conditioning Compressors, Industrial Pumping Equipment and Shipboard Applications. The ease of installation makes it suitable for numerous other applications.

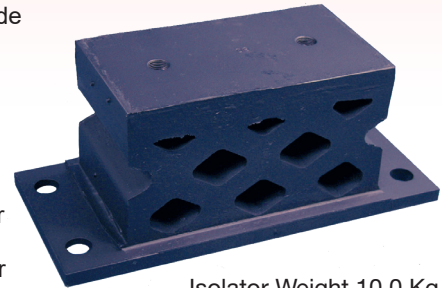

Isolator Weight 10.0 Kg

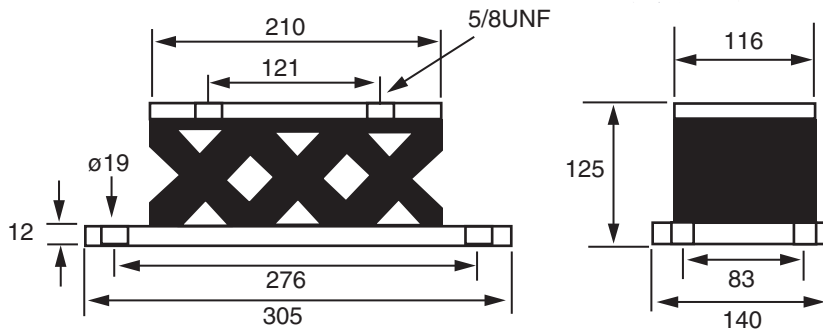

Part No.	COMPRESSION		SHEAR		Part No.	COMPRESSION		SHEAR	
	LOAD Kg	DEF mm	LOAD Kg	DEF mm		LOAD Kg	DEF mm	LOAD Kg	DEFmm
M18840	50	4	25	5	M18875	100	1	100	5
	100	7	50	10		200	2	200	9
	150	11	75	15		300	3	300	14
	200	14	100	20		400	5	400	20
	250	18	125	25		500	6	470	25
	300	21				600	8		
	350	25				700	10		
M18860	100	2	50	5		800	11		
	200	4	100	9		900	13		
	300	7	150	13		1000	16		
	400	10	200	18		1100	18		
	500	12	250	22		1200	21		
	600	17	300	28		1300	24		
	700	22				1400	26		
	800	28							

TYPICAL INSTALLATION ARRANGEMENT:

These Hy-Deflection Isolators are recommended for use where the disturbing or forced frequency is as low as 5 hertz. Their lattice design provides a soft vertical spring rate combined with lateral stability. This isolator is intended for anti-vibration applications where high static deflections is required; but is not suitable for applications involving repetitive shock load.

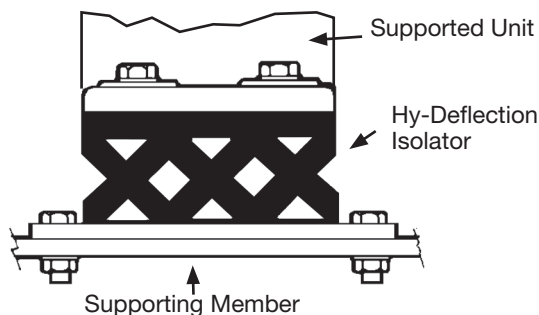

HY-DEFLECTION DOME MOUNT

These mounts offer great elasticity in the radial an axial direction. Their internal design makes them ideal mounts for machines that produce vibrations in 3 directions. The design of the mounts facilitates easy installation. The top metal part has an inside thread for securing to the machine, with two passing screw holes for the flange for securing to the bed plate.

- The metal parts are electrolytic coated to protect against corrosion.
- The rubber hardness is engraved on the metal parts

APPLICATIONS:

- Compressors
- Air-conditioners
- Ventilators
- Vibrating Tables

Replaces “M” Type Isolators



M175031
M175036
M175041

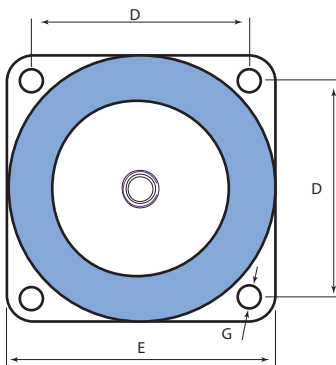

M175001
M175003
M175021

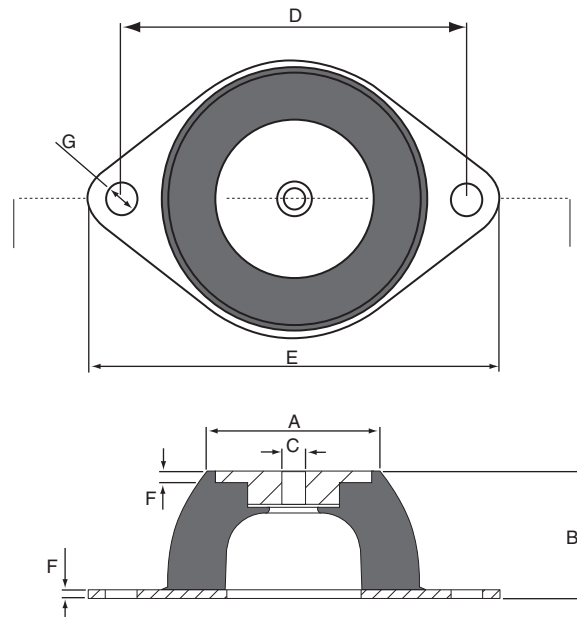

Part No.	A	B	C	D	E	F	G	Load Kg	Deflection mm	Weight KgM
M175001	52	35	M10	92	114	2.5	10.5	40	4	.17
M175003	52	40	M10	110	136	3	11.5	75	11	.3
M175021	57.5	45	M10	125	150	3	12.5	130	9	.43
M175031	76	63.5	M12	120	150	5	14.5	280	14	1.35
M175036	100	84	M16	160	200	4	14.5	380	18	2.39
M175041	187	158	M24	250	310	6	18.5	1400	50	10.4