

## SLIMLINE ISOLATORS

SlimLine machinery isolators offer increased protection to the rubber element in applications where it is considered necessary. The series provide excellent isolation efficiency with an equal load capacity in both compression and shear.

They are suitable for all applications where restraint in horizontal movement is required but good isolation is needed in the vertical plane.

- SlimLine Two Hole Mounting
- Elongated Universal Mounting Holes
- Low Profile to Reduce Centre of Gravity
- Available in 3 Elastomer Hardnesses:

40 Duro

55 Duro

65 Duro

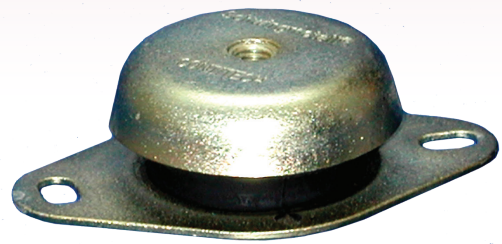

**M510 SLIMLINE SERIES**

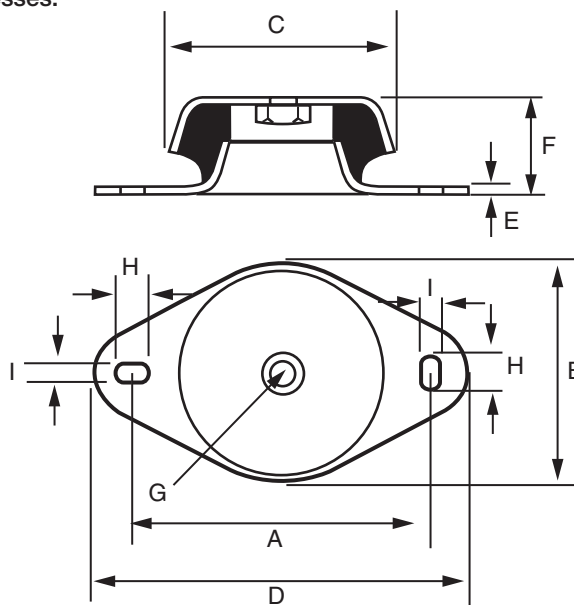

| Part No.   | DIMENSIONS |    |    |     |   |    |     |    |   | Weight Kg |
|------------|------------|----|----|-----|---|----|-----|----|---|-----------|
|            | A          | B  | C  | D   | E | F  | G   | H  | I |           |
| M510103965 |            |    |    |     |   |    |     |    |   |           |
| 40-55-65   | 96         | 76 | 72 | 122 | 2 | 33 | M10 | 15 | 9 | 0.3       |

| LOAD RATING CHART |                      |               |
|-------------------|----------------------|---------------|
| Part No.          | COMPRESSION OR SHEAR |               |
|                   | LOAD Kg              | DEFLECTION mm |
| M51010396540      | 50                   | 1.39          |
|                   | 100                  | 2.67          |
|                   | 150                  | 3.72          |
|                   | 200                  | 4.71          |
| M51010396555      | 50                   | 0.94          |
|                   | 100                  | 1.71          |
|                   | 150                  | 2.52          |
|                   | 200                  | 3.23          |
| M51010396565      | 250                  | 4.04          |
|                   | 50                   | 0.50          |
|                   | 100                  | 1.00          |
|                   | 150                  | 1.50          |
|                   | 200                  | 2.00          |
|                   | 250                  | 2.50          |
|                   | 300                  | 3.00          |

\*Duro rating stamped on Base